



Otto Lilienthal
MUSEUM

UNITED STATES PATENT OFFICE.

OTTO LILIENTHAL, OF BERLIN, GERMANY.

FLYING-MACHINE.

SPECIFICATION forming part of Letters Patent No. 514,816, dated August 20, 1895.

Application filed February 28, 1894. Serial No. 601,880. (No model.)

To all whom it may concern:

Be it known that I, OTTO LILIENTHAL, manufacturer, a subject of the German Emperor, and a resident of Berlin, German Empire, have invented certain new and useful Improvements in Flying-Machines, of which the following is a specification.

This invention relates to flying-machines which resemble in their construction the structure of birds' wings. The object of these flying-machines is to imitate the soaring of birds as well as their ordinary flight, which is effected by the flapping of the wings. The improved machine comprises two wings, which, after the manner of birds' wings, are slightly vaulted upward. These wings are fixed by two rods laid crosswise one upon the other and firmly connected together, which rods form a carrying-frame or part of a carrying-frame to which the person intending to fly may hold, so as to be suspended between the two wings.

In the accompanying drawings the flying-machine, constructed according to the present invention, is represented in Figures 1 to 5.

Fig. 1 shows a view from above of this flying-machine. Figs. 2, 3, and 4 are sections on the lines A B, C D, and E F of Fig. 1. Fig. 5 shows the flying-machine when folded up.

In carrying this invention into practice, two wooden rods *a*, forming an acute-angled cross, are arranged to carry at their upper ends *b* pockets *d*, produced by two small wooden plates. In these pockets are pivoted the wooden ribs *e* of the wings. A string *f*, connecting the points of the ribs, and a wire *g*, fastened to the first rib of the wing and hooked to the hoop *h*, stretch these ribs in the horizontal direction. The tension downward is given to the ribs by wires *i*, which extend from the points *k* of the ribs to the lower ends *c* of the crossed rods *a*. Cushions *l* are fixed between the crossed rods *a*. The said hoop *h* is nailed, glued, or otherwise secured in the pockets *d*.

With this hoop are firmly connected the rods *m*, to which are attached in front the wooden bar *n*, with the rods *o o*, and at the rear two diverging rods *p*. On the latter is pivoted the tail *q* in such a manner that it can freely turn upward, but finds downward a point of support on the fixed rudder *r*. This mode of at-

taching the tail has the advantage that the tail will have no carrying action when the machine is employed like an ordinary parachute, thereby preventing the machine from turning over forward. The rudder *r*, which serves for automatically keeping the machine in the wind's eye, is likewise detachably fastened to the rods *m* and the hoop *h*. The surfaces of the machine over which fabric is stretched are shaded in the right-hand half of Fig. 1.

For using this flying-machine the person inserts his fore-arms between the cushions *l*, fixed to the crossed wooden rods *a*, Fig. 3, and takes hold of the bar *n* with the hands, so that, without changing the upright position of his body, he can carry and properly adjust the machine in a very convenient manner during his run before the flight, while during the flight he can balance and steer the machine, in which he is suspended, by a suitable movement of his body, so as to displace its center of gravity. In this manner he can imitate the so-called "soaring" of birds, in which the movement takes place merely by a change in the position of the wings with regard to the direction of the wind, there being no rudder movement proper of the wings. As under these circumstances the legs are always freely suspended downward the landing can safely be effected by putting the feet on the ground.

The folding up of the machine is effected by disengaging the front tension-wires *g* from the hoop *h*, turning the ribs about their center in the pockets *d* to the rear and hooking the tension-wires *g* into the eyes on the rods *m*. The apparatus then constitutes a compact whole.

Having now particularly described and ascertained the nature of my said invention and in what manner the same is to be performed, I declare that what I claim, and desire to secure by Letters Patent of the United States of America, is—

1. In a flying machine, the combination of two crossed carrying rods *a*, two wings vaulted upward, and strings or wires *i* extending from the ends of the carrying rods toward the peripheries of the wings, substantially as set forth.

2. In a flying machine, the combination of

two crossed carrying rods *a*, two wings vaulted upward, strings or wires *i* connecting the two carrying rods with the wings, and a vertical fixed rudder substantially as set forth.

5 3. In a flying machine, the combination of a crossed frame, two wings connected therewith, strings or wires *i*, a vertical fixed rudder *r* and a horizontal tail *q*, adapted to turn upward automatically, substantially as set forth.

10 4. In a flying machine, the combination with a supporting frame, of a wing adapted to be folded together and having its ribs diverging from a common support, and suitably hinged thereto a string connecting the outer
15 points of the ribs, and continuous fabric attached to a series of ribs, substantially as set forth.

5. In a flying machine, the combination with a supporting frame comprising a hoop,
20 of a wing having its ribs diverging from a common support, a string connecting the outer points of the ribs, a wire, as *g*, fastened to the first rib of the wing and attached to the hoop and fabric stretched over the ribs and such
25 wire, substantially as set forth.

6. In a flying machine, the combination with a supporting frame, of a wing having its ribs diverging from a common support, fabric stretched over the ribs and wires, as *i*, extending from the ribs downward to the sup-
30 porting frame for the purpose of adjusting

thereby the tension of the ribs, substantially as set forth.

7. In a flying machine, the combination with a frame comprising a hoop and crossed
35 bars connected therewith, of wings supported by said frame, substantially as set forth.

8. In a flying machine, a supporting frame for the wings comprising a hoop *h*, rods extending from it for supporting the operator
40 and a tail and a rudder, and pockets as *d* for receiving the ends of the ribs of the wings, substantially as set forth.

9. In a flying machine the combination with a supporting frame, of wings with suit-
45 able ribs connected therewith, front tension wires *g*, and pockets *d* for receiving the inner ends of the ribs, the ribs being made capable of turning around their centers in such pockets for the purpose of folding up such wings,
50 substantially as set forth.

10. In a flying machine, the combination with a supporting frame, of wings, a fixed rudder and a pivoted tail adjusted to come to rest upon the rudder when swinging down-
55 ward, substantially as set forth.

Signed at Berlin this 1st day of February, 1894.

OTTO LILIENTHAL.

Witnesses:

HERMAN MULLER,
REINHOLD WEIDNER.



Otto Lilienthal
MUSEUM

Digitalisat aus dem Archiv des

O. LILIENTHAL.
FLYING MACHINE.

No. 544,816

Patented Aug. 20, 1895.

Fig I.

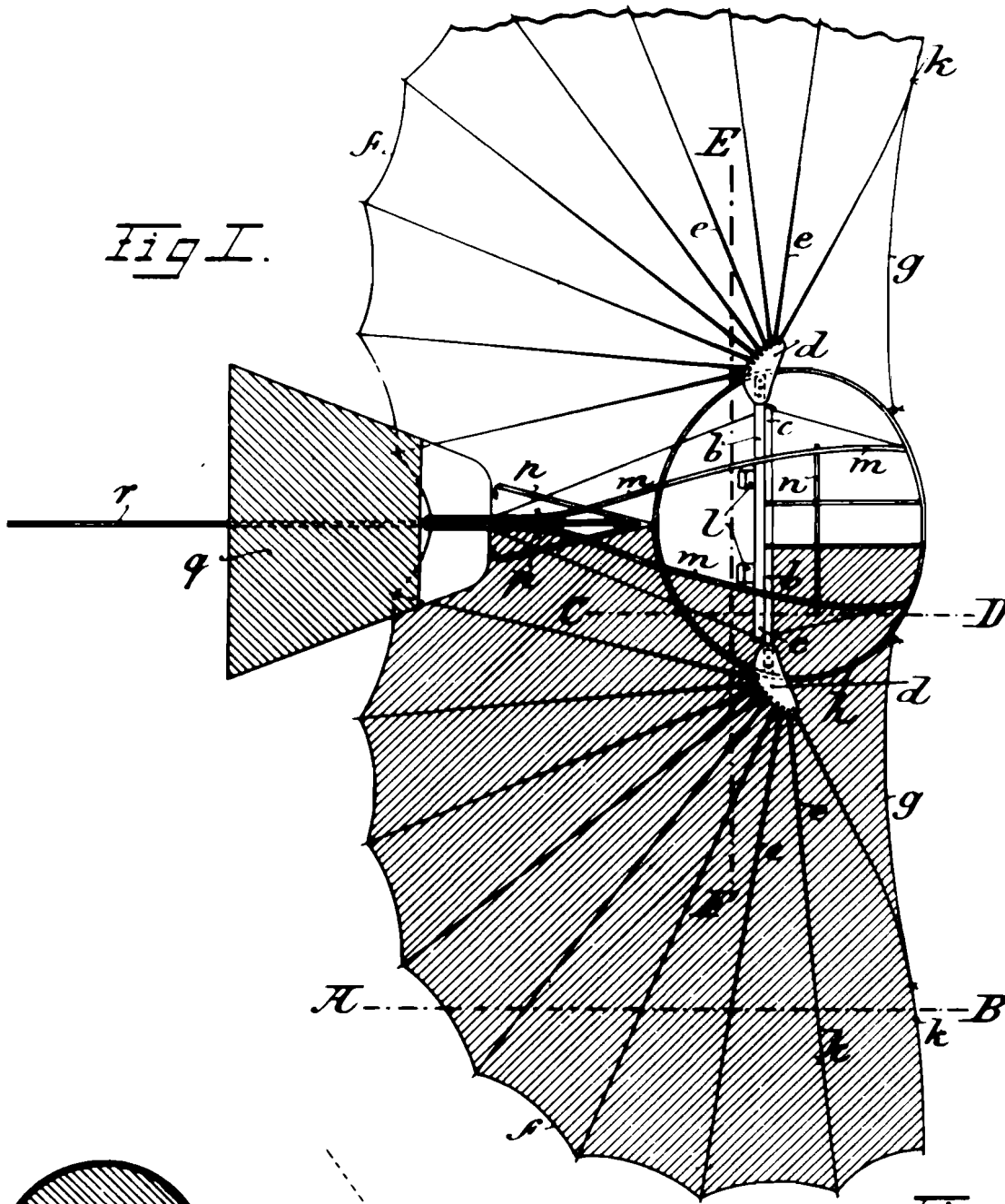

Fig II.

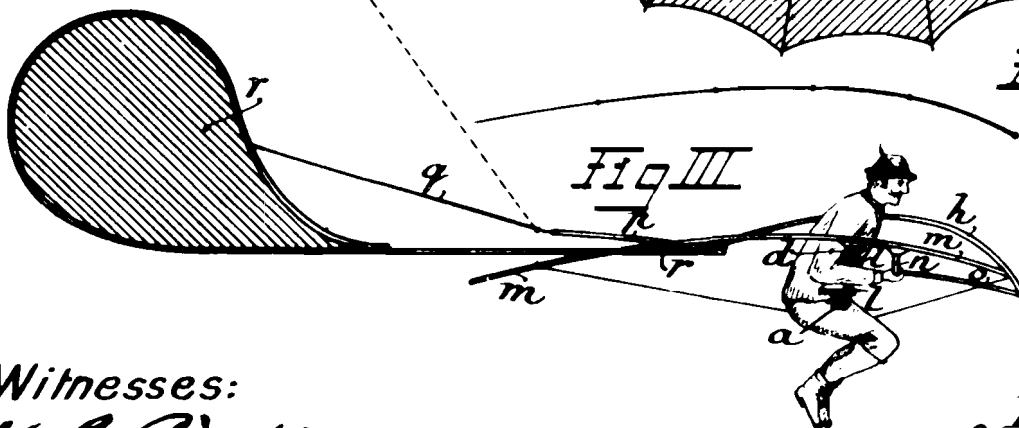

Fig III

Witnesses:

W. C. Pinkney
W. E. Bowen

Inventor:

Otto Lilienthal

By Attorney:

J. M. Bowen

(No Model.)

2 Sheets—Sheet 2.

O. LILIENTHAL.
FLYING MACHINE.

No. 544,816.

Patented Aug. 20, 1895.

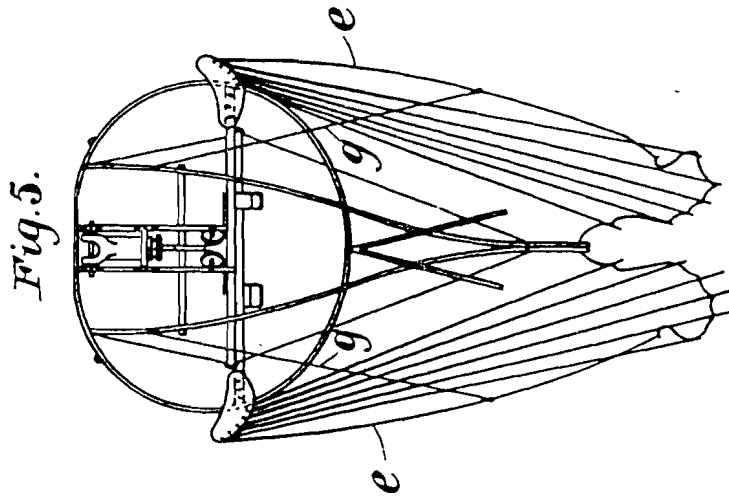
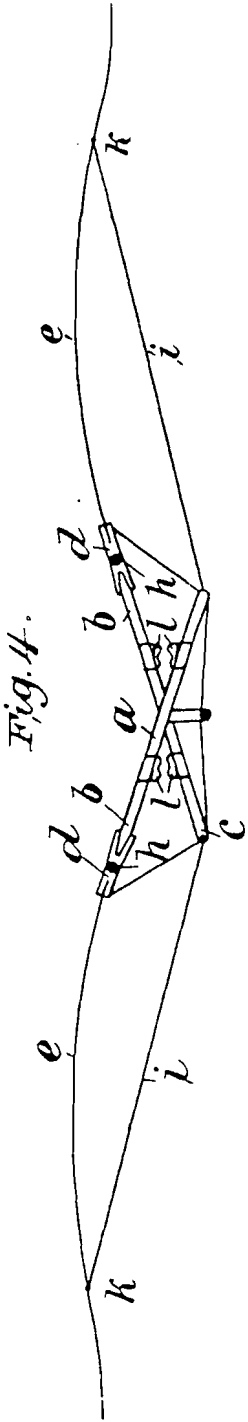

Witnesses:-
 W. C. Pinckney
 L. Holloway.

Inventor:
 Otto Lilienthal,
 By J. M. Boren
 Attorney.